



REVERSE ENGINEERING & RETROFIT SOLUTIONS



POWERING AFRICA'S FUTURE:
INNOVATIVE ASSET INTEGRITY & INDUSTRIAL SOLUTIONS

www.dgc-africa.com

SOUTH AFRICA

ZAMBIA

DEMOCRATIC REPUBLIC OF CONGO

MADAGASCAR

ZIMBABWE

BRAZIL

CHINA

REVERSE ENGINEERING & RETROFIT SOLUTIONS



DGC AFRICA, a division of the Dickinson Group of Companies, is a leading provider of asset integrity management and industrial solutions across sub-Saharan Africa. With a rich heritage spanning 115 years, **DGC AFRICA** has established itself as a trusted partner in the mining, metals smelting, mineral processing, and various other heavy industries.

Our comprehensive range of services includes reverse engineering, retrofit solutions, furnace and smelter solutions, industrial cleaning, mechanical engineering, and specialized industrial products.

DGC AFRICA'S COMMITMENT TO
**INNOVATION, SAFETY,
& CUSTOMER-CENTRIC**
SOLUTIONS HAS POSITIONED
US AT THE FOREFRONT
OF INDUSTRIAL SERVICES IN AFRICA

Our extensive experience, coupled with our deep understanding of local markets, enables us to deliver tailored, high-quality solutions that meet the unique challenges of our diverse client base.



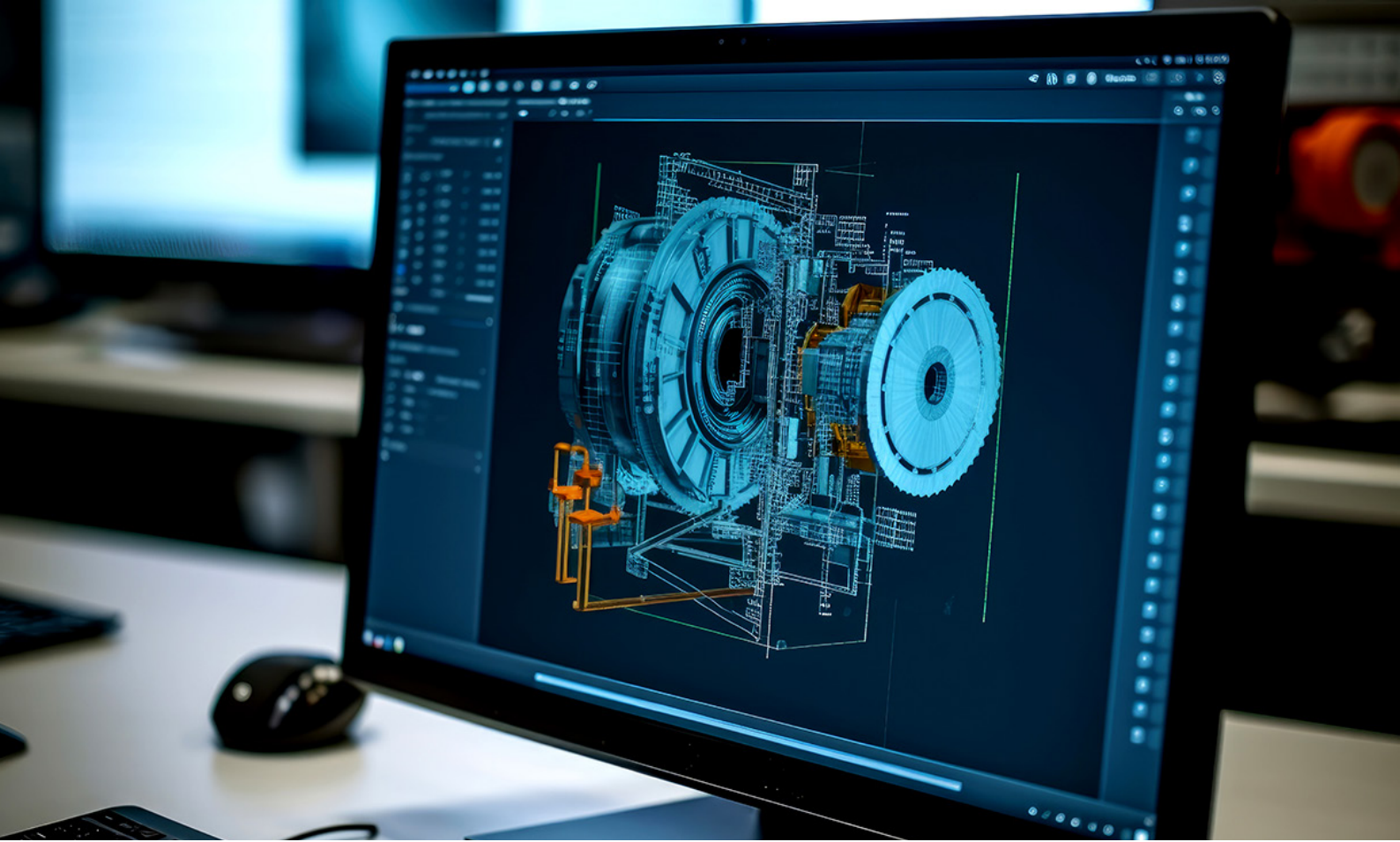

Effixon Engineering is an industry leader in delivering expert reverse engineering and retrofit solutions. Their meticulous approach ensures that existing equipment and systems are thoroughly analysed and optimized for enhanced performance, safety, and longevity. By leveraging advanced techniques and technologies, Effixon Engineering provides tailored solutions that extend the lifecycle of assets, improve operational efficiency, and meet the highest standards of quality. Their expertise ensures that every retrofit and reverse engineering project results in reliable and cost-effective improvements for various industrial applications.

AT DGC AFRICA & EFFIXON ENGINEERING,
**OUR REVERSE ENGINEERING
& RETROFIT SOLUTIONS
ARE DESIGNED TO OPTIMIZE
EXISTING EQUIPMENT, ENHANCE PERFORMANCE,
& EXTEND THE LIFESPAN**
OF CRITICAL INDUSTRIAL ASSETS ACROSS DIVERSE SECTORS.
LEVERAGING STATE-OF-THE-ART TECHNOLOGY
& **DEEP INDUSTRY EXPERTISE,**
OUR COMBINED TEAMS DELIVER SPECIALIZED
**REVERSE ENGINEERING & RETROFIT SERVICES
TAILORED TO THE UNIQUE CHALLENGES OF EACH FACILITY**

OUR COMPREHENSIVE

REVERSE ENGINEERING & RETROFIT SOLUTIONS

PRECISE DATA CAPTURE | DETAILED ANALYSIS | DESIGN RECREATION

MATERIAL & COMPONENT EVALUATION | IMPROVED EFFICIENCY | ENHANCED SAFETY

EXTENDED LIFESPAN | COMPATIBILITY ASSURANCE | CUSTOM SOLUTIONS | QUALITY ASSURANCE

PRECISE DATA CAPTURE



UTILIZING ADVANCED
TECHNIQUES TO CAPTURE
ACCURATE MEASUREMENTS,
DIMENSIONS, &
PERFORMANCE DATA
FROM ORIGINAL EQUIPMENT OR SYSTEMS

Our **Precise Data Capture** service forms the foundation of our reverse engineering process. Using cutting-edge 3D scanning technology, photogrammetry, and advanced measurement tools, we create highly accurate digital representations of your existing equipment and systems. This meticulous approach ensures that every detail is captured, providing a solid basis for analysis and redesign. Our process minimizes disruption to your operations while maximizing the accuracy and completeness of the data collected.

DETAILED ANALYSIS

Our **Detailed Analysis** service goes beyond surface-level examination. Our team of expert engineers employs advanced computational techniques, including Finite Element Analysis (FEA) and Computational Fluid Dynamics (CFD), to gain deep insights into the performance and behaviour of your equipment.

CONDUCTING THOROUGH ANALYSIS
OF COLLECTED DATA TO UNDERSTAND
DESIGN, FUNCTIONALITY,
& AREAS FOR IMPROVEMENT

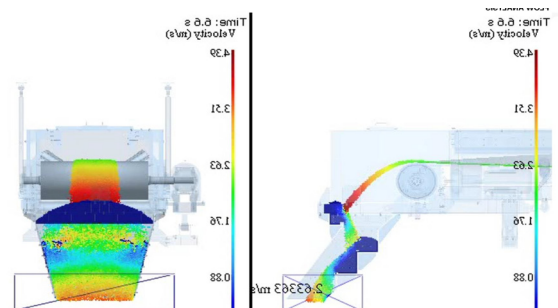

We analyse stress points, fluid flows, thermal distributions, and other critical factors to identify areas of improvement and optimization. This comprehensive analysis forms the basis for our redesign and retrofit recommendations, ensuring that every modification is backed by solid engineering principles.

DESIGN RECREATION



RECREATING ACCURATE DESIGN SPECIFICATIONS, DRAWINGS, & DOCUMENTATION USING ANALYZED DATA

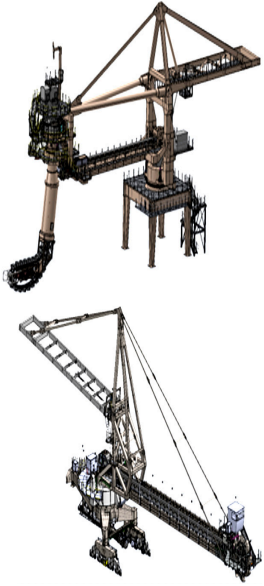

Our Design Recreation service transforms raw data and analysis into practical, usable designs. Using state-of-the-art CAD software, we create detailed 3D models and 2D drawings that accurately represent your equipment, including any improvements or modifications identified during the analysis phase.

These recreated designs serve as the blueprint for retrofits, replacements, or improvements. They also provide valuable documentation for future maintenance and modifications, enhancing your asset management capabilities.

MATERIAL & COMPONENT EVALUATION

Our Material and Component Evaluation service ensures that every part of your system is optimized for its specific role. We conduct in-depth analyses of existing materials and components, considering factors such as wear resistance, thermal properties, chemical compatibility, and mechanical strength.

ASSESSING MATERIALS & COMPONENTS USED IN ORIGINAL EQUIPMENT TO DETERMINE SUITABILITY FOR INTENDED APPLICATION

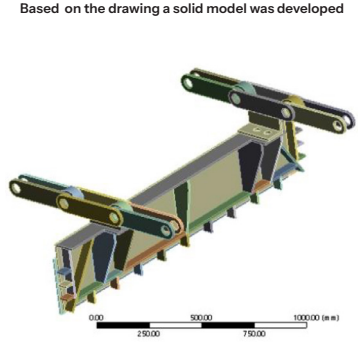
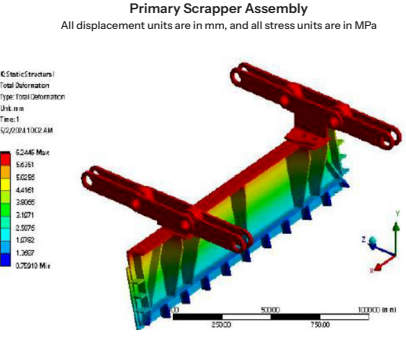

Based on these evaluations, we recommend material upgrades or component replacements that can significantly enhance the performance and longevity of your equipment. Our recommendations are always balanced with cost considerations, ensuring you get the best value for your investment.

IMPROVED EFFICIENCY

Our Improved Efficiency service focuses on optimizing your systems for maximum output with minimum input. Through careful analysis and innovative redesign, we identify and eliminate bottlenecks, reduce energy consumption, and streamline processes.

Whether it's upgrading control systems, redesigning fluid pathways, or implementing more efficient components, our solutions are tailored to significantly boost your operational efficiency. The result is reduced operational costs, increased productivity, and improved competitiveness in your industry.

REDESIGNING &
UPGRADING
SYSTEMS TO IMPROVE
EFFICIENCY, REDUCE
ENERGY CONSUMPTION,
& ENHANCE OVERALL
PERFORMANCE

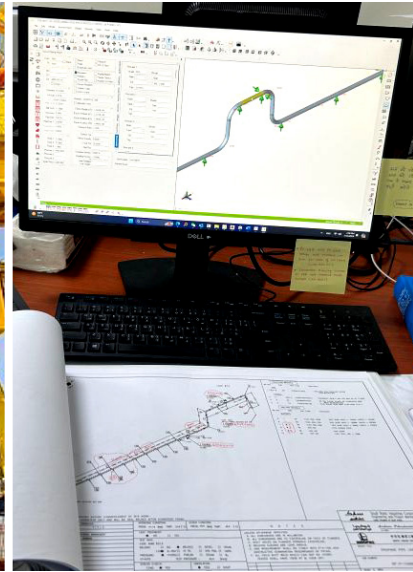

ENHANCED SAFETY

Safety is paramount in all industrial operations. Our Enhanced Safety service ensures that your retrofitted systems not only perform better but also meet or exceed the latest safety standards. We conduct comprehensive safety audits, identify potential hazards, and implement robust safety measures.

From upgrading guarding systems to implementing advanced safety controls, we ensure that your equipment protects your most valuable asset – your workforce. Our safety enhancements often go hand-in-hand with improved operability, creating a win-win situation for safety and productivity.

IMPLEMENTING SAFETY
ENHANCEMENTS
TO ALIGN EQUIPMENT
& SYSTEMS WITH
CURRENT SAFETY
STANDARDS & REGULATIONS



EXTENDED LIFESPAN

Our **Extended Lifespan service** is about maximizing the return on your capital investments. Through strategic upgrades and retrofits, we breathe new life into aging equipment, postponing the need for costly total replacements.

We identify critical wear points, upgrade vulnerable components, and implement modern technologies that can significantly extend the operational life of your systems. This approach not only saves on capital expenditure but also reduces downtime and maintenance costs over the long term.



DESIGNING RETROFIT
SOLUTIONS TO
EXTEND EQUIPMENT
& SYSTEM LIFESPAN,
REDUCING THE NEED
FOR COSTLY
REPLACEMENTS



COMPATIBILITY ASSURANCE

Our **Compatibility Assurance service** guarantees that all retrofits and upgrades work harmoniously with your existing systems. We conduct thorough interface analyses, ensuring that new components are fully compatible with your current infrastructure, control systems, and operational procedures.

This service minimizes disruption during implementation and ensures smooth operation post-retrofit. We also provide comprehensive documentation and training to ensure your team is fully equipped to operate and maintain the upgraded systems.

ENSURING
SEAMLESS
INTEGRATION
OF RETROFITTED
COMPONENTS
& SYSTEMS
WITH EXISTING
INFRASTRUCTURE



CUSTOM SOLUTIONS

Every industrial operation is unique, and off-the-shelf solutions often fall short. **Our Custom Solutions service** provides bespoke engineering solutions tailored to your specific needs. Whether you're dealing with obsolete equipment, unique operational challenges, or specific performance requirements, we develop solutions that fit perfectly.

Our team works closely with you to understand your goals, constraints, and preferences, ensuring that the final solution not only meets but exceeds your expectations. From custom-designed components to entire system overhauls, we have the expertise to bring your vision to life.

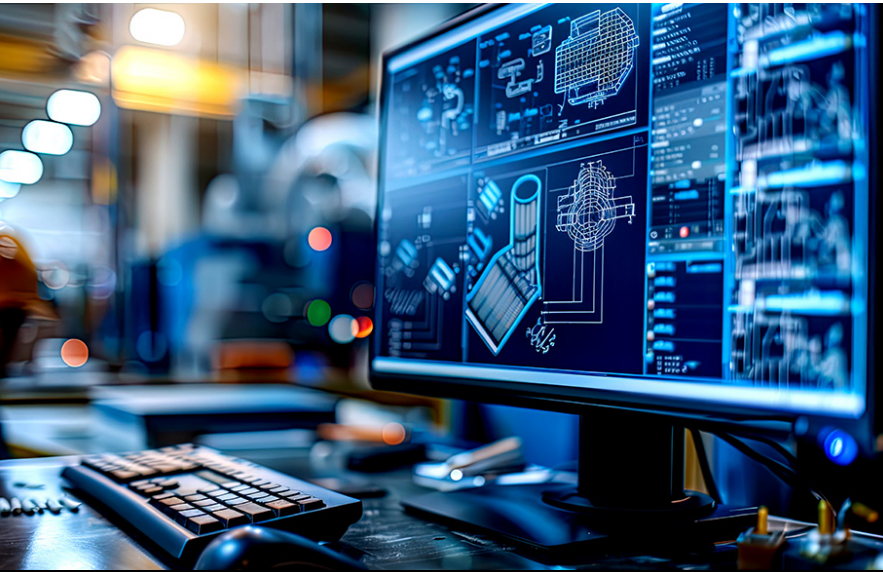

TAILORING REVERSE ENGINEERING & RETROFIT SOLUTIONS TO THE UNIQUE REQUIREMENTS OF YOUR EQUIPMENT & SYSTEMS

IMPLEMENTING RIGOROUS TESTING & VALIDATION TO ENSURE SOLUTIONS MEET THE HIGHEST STANDARDS FOR PERFORMANCE, EFFICIENCY, SAFETY, AND COMPLIANCE

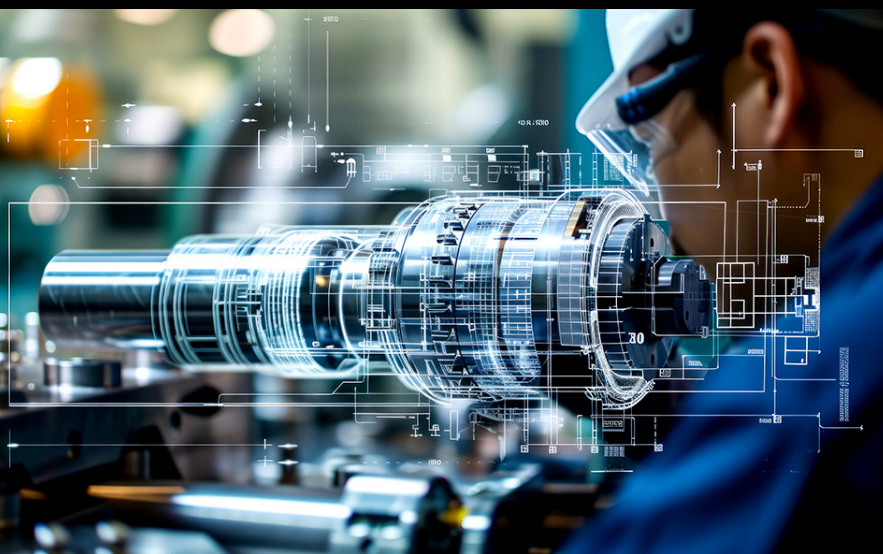

QUALITY ASSURANCE

Quality is at the core of everything we do. **Our Quality Assurance service** ensures that all our reverse engineering and retrofit solutions meet the highest standards of performance, reliability, and safety.

We implement comprehensive testing protocols, including factory acceptance tests, site acceptance tests, and performance validation.

Our quality assurance process doesn't end at implementation. We provide ongoing support, monitoring, and optimization to ensure that your retrofitted systems continue to perform at peak efficiency over time. With DGC AFRICA and Effixon Engineering, quality isn't just a promise – it's a guarantee.

CASE STUDY



SHIP UNLOADER (GRAB TYPE) MAIN & AUXILIARY TROLLEY RE-DESIGN

CLIENT: Chennai Radha Engineering Private Limited
END CUSTOMER: TANGEDCO (Tamil Nadu Electricity Board), Chennai, India

CHALLENGE

- Vibration and rusting of main members/plates in Main and Auxiliary trolley
- No detailed drawings available
- Machine couldn't be stopped due to uninterrupted coal supply for power generation

SOLUTION

- Effixon engineers measured dimensions during operation and ship interchanges
- Developed preliminary 3D model based on GA drawing and site measurements
- Conducted FEA with different loading conditions to ensure stability
- Updated 3D model and prepared 2D fabrication drawings for manufacturing

OUTCOME

Successfully redesigned trolleys, addressing vibration and rusting issues while maintaining operational continuity.

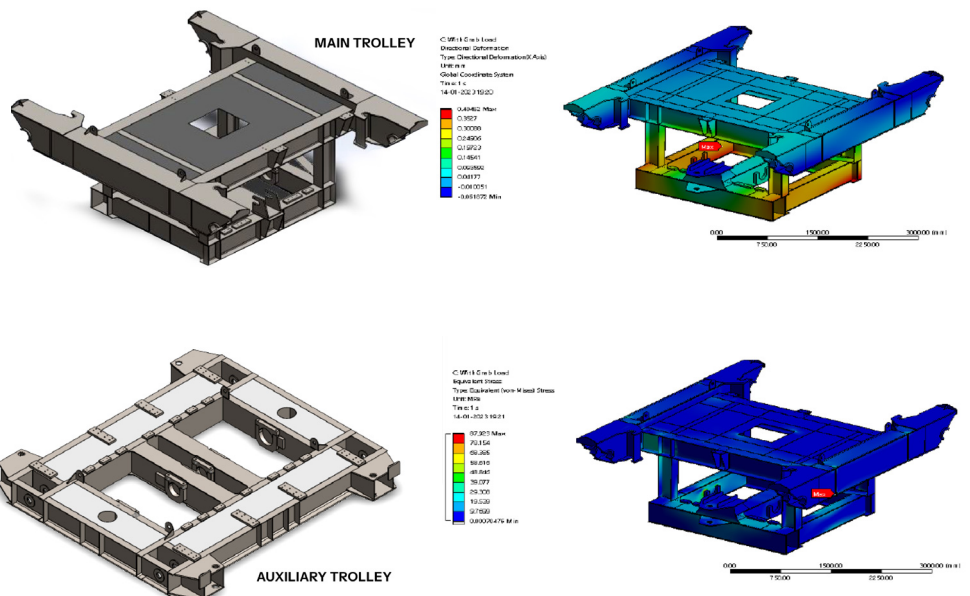



CIRCULAR STOCKPILE STACKER RECLAIMER BUCKET REDESIGN

CLIENT: Oreteq Pty Ltd, Australia

CHALLENGE

Bucket blockage and poor pouring efficiency after passing the chute zone

SOLUTION

- Utilized existing drawings, site photos, and 3D scans
- Developed new 3D model and 2D fabrication drawings

OUTCOME

Redesigned bucket to eliminate blockage and improve material handling efficiency for sticky materials.

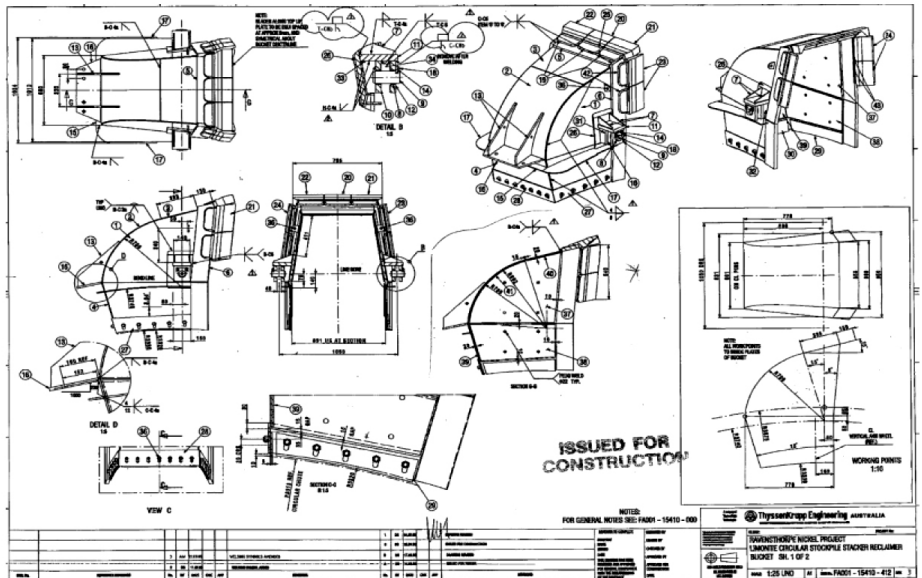
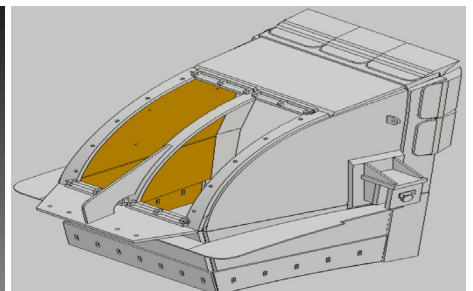
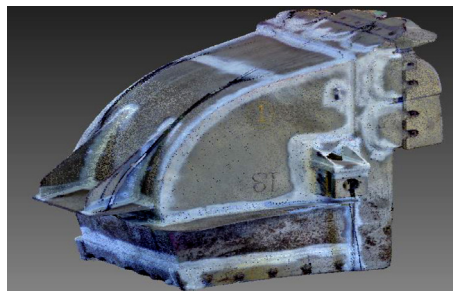

CASE STUDY

ANALYSIS & BALANCING OF BUCKET WHEEL STACKER & RECLAIMER COUNTERWEIGHT

CLIENT: IL&FS Tamil Nadu Power Company Limited, Tamil Nadu, India

ISSUE

Three BWS Reclaimers facing problems with slewing ring bearing due to improper mass balancing of counterweight and pressure equalization.

SCOPE

- Analyse machine balance by comparing with designed loads
- Provide solutions to improve bearing lifespan
- Perform calculations based on available drawings and site measurements

OUTCOME

Delivered balanced design recommendations to extend the life of critical components and improve overall machine performance.

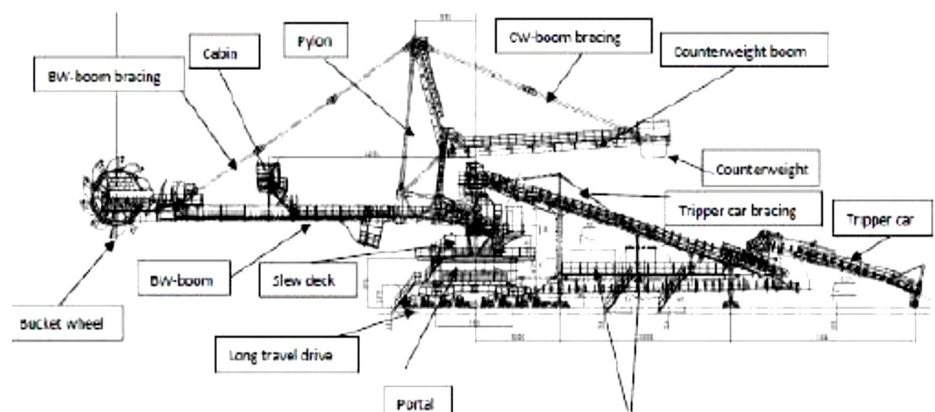
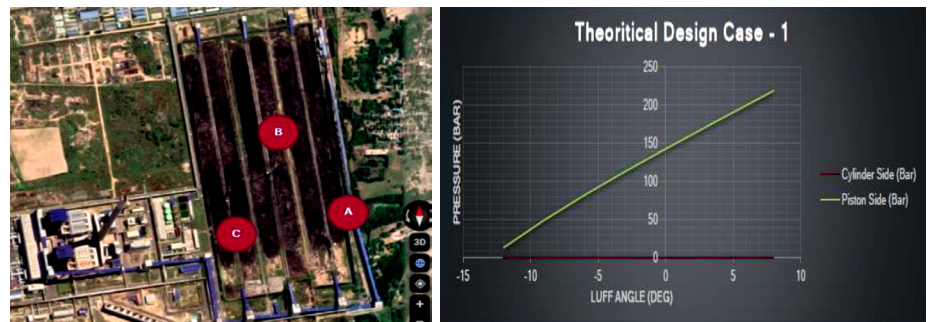



ELEVATE YOUR **INDUSTRIAL PERFORMANCE**

Contact us today to schedule a comprehensive assessment of your systems and equipment. Our experts are ready to develop a tailored reverse engineering and retrofit solution that will optimize your operations, reduce downtime, and drive long-term efficiency.

TRANSFORM YOUR INDUSTRIAL PERFORMANCE

LET'S BUILD A MORE EFFICIENT & SUSTAINABLE
FUTURE TOGETHER.

TAKE **THE NEXT STEP**

Through our Reverse Engineering & Retrofit Solutions, **DGC AFRICA** and Effixon Engineering ensure the technical upgrading of facilities while fostering a culture of innovation and environmental stewardship. Join us to set the industry standard, enhance productivity, and promote sustainability across various industrial sectors. Partnering with **DGC AFRICA** and Effixon Engineering means investing in the future of your operations, where optimized equipment, enhanced operational efficiency, and reliable performance are guaranteed.



DGC INTERNATIONAL

E International@dgc-africa.com

2nd Floor, The AXIS,
26 Bank Street,
Cybercity,
Ebene, 72201,
Mauritius

DGC SOUTH AFRICA

Contact Person: Wynand Boshoff

T +27 16 421 3720
E sales@dgrpint.com

10 Smuts Avenue, Vereeniging,
1930, South Africa

REGIONAL OPERATIONS

DGC NORTH-WEST

Contact Person: Gawie Hugo

T +27 83 391 0531
E Northwest@dgc-africa.com

DGC KWA-ZULU NATAL

Contact Person: Denver Gounden

T +27 73 161 9913
E Kzn@dgc-africa.com

DGC LIMPOPO

Contact Person: Walter Mulovhedzi

T +27 76 896 7676
E Limpopo@dgc-africa.com

DGC ZAMBIA

Contact Person: Warren du Plessis

T +260 761 83 2470
T +27 82 319 8005
E Zambia@dgc-africa.com

Plot 2394, Freedom Way,
Mufulira

DGC DEMOCRATIC REPUBLIC OF CONGO

Contact Person: Warren du Plessis

T +243 8996 49 493
T +27 82 319 8005
E DRC@dgc-africa.com

Kolwesi Office:

118 Avenue Kalima, Quartier Mutoshi,
Commune Manika / Kolwezi

Lubumbashi Office:

199 Avenue Mubanzo Quartier; Golf Malela.
Commune Lubumbashi,
Province du Haut-Katanga, République
démocratique du Congo

DGC MADAGASCAR

Contact Person: Abizar Pichori

T +261 32 112 2122
E Madagascar@dgc-africa.com

Lot Ivx 30 Bis Ankazomanga rue
Dr Raseta Antananarivo, 101,
Madagascar

DGC ZIMBABWE

Contact Person: Douglas Mhazo

T +263 772 514 480
E Zimbabwe@dgc-africa.com

311 Esap Way, Willowvale
Harare, Zimbabwe

DGC LATAM

Contact Person: José Diniz

T +55 31 9961 82402
E Brazil@dgc-africa.com

1200, Carlos Alves dos Santos St.
35.702-000 - Industrial District
- Matozinhos Minas Gerais, Brazil

OUR OFFICES



www.dgc-africa.com